



# Instructions



**EN** ENGLISH

**ES** ESPAÑOL

**FR** FRANÇAIS

**DE** DEUTSCH

**RU** РУССКИЙ



**HIGH VOLUME HOSE REELS - 5088 SERIES**  
RM150

2026\_04\_24-12:22

# Main Instruction Book Includes All Languages

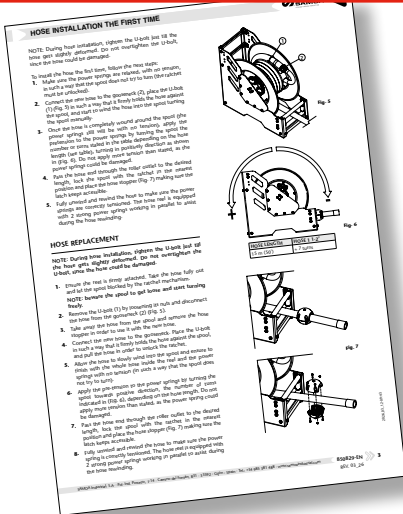

# Maintenance Spare Parts Kits

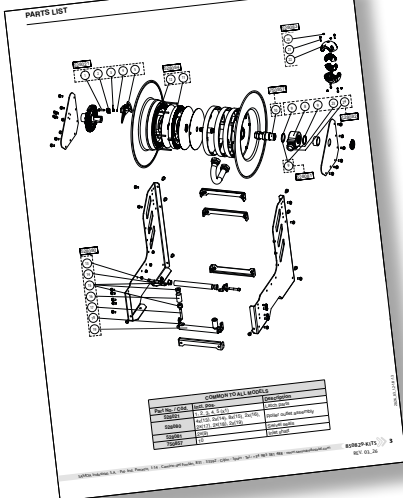



# Instruction books By Language Requested

**EN**  
INSTRUCTIONS



**ES**  
INSTRUCCIONES



**FR**  
INSTRUCTIONS



**DE**  
BEDIENUNGS-  
ANLEITUNG



**RU**  
ИНСТРУКЦИИ



**WARNING / ADVERTENCIA / AVERTISSEMENT / WARNUNG / ПРЕДУПРЕЖДЕНИЕ**

Carefully read user manual and its warnings before using the equipment.

*Lea atentamente el manual de instrucciones y sus advertencias antes de empezar a operar con el equipo.*

Lisez attentivement le manuel d'instructions et les avertissements qu'il contient avant de commencer l'utilisation de l'appareil.

*Lesen Sie das Benutzerhandbuch und die darin enthaltenen Warnhinweise sorgfältig durch, bevor Sie das Gerät benutzen*

**ВНИМАТЕЛЬНО ПРОЧИТАЙТЕ ИНСТРУКЦИЮ И ПРЕДУПРЕЖДЕНИЯ ПЕРЕД НАЧАЛОМ РАБОТЫ С ОБОРУДОВАНИЕМ**

2026\_04\_24-12:22

**EC CONFORMITY DECLARATION / DECLARATION CE DE CONFORMIDAD  
DÉCLARATION DE CONFORMITÉ CE / EG-KONFORMITÄTSEKTLÄRUN /  
DECLARAÇÃO CE DE CONFORMIDADE**



**EN** **SAMOA INDUSTRIAL, S.A.**, Pol. Ind. Porceyo, I-14 · Camino del Fontán, 831 · 33392 - Gijón - Spain, declares that the product(s): **5088XX, 5088XX.XXX** conform(s) with the EU Directive(s): **2006/42/CE**

**ES** **SAMOA INDUSTRIAL, S.A.**, Pol. Ind. Porceyo, I-14 · Camino del Fontán, 831 · 33392 - Gijón - España, declara que el(los) producto(s): **5088XX, 5088XX.XXX** cumple(n) con la(s) Directiva(s) de la Unión Europea: **2006/42/CE**

**FR** **SAMOA INDUSTRIAL, S.A.**, Pol. Ind. Porceyo, I-14 · Camino del Fontán, 831 · 33392 - Gijón- Espagne, déclare que le(s) produit(s): **5088XX, 5088XX.XXX** est(sont) conforme(s) à la (aux) directive(s) européenne(s): **2006/42/CE**

**DE** **SAMOA INDUSTRIAL, S.A.**, Pol. Ind. Porceyo, I-14 · Camino del Fontán, 831 · 33392 - Gijón- Spanien, bestätigt hiermit, dass das (die) Produkt (e): **5088XX, 5088XX.XXX** der (den) EG-Richtlinie(n): **2006/42/CE** entspricht (entsprechen).

For SAMOA INDUSTRIAL, S.A.  
Por SAMOA INDUSTRIAL, S.A.  
Pour SAMOA INDUSTRIAL, S.A.  
Für SAMOA INDUSTRIAL, S.A.

**Pedro E. Prallong Álvarez**  
Production Director  
Director de Producción  
Directeur de Production  
Produktionsleiter