

Instructions

EN ENGLISH

ES ESPAÑOL

FR FRANÇAIS

DE DEUTSCH

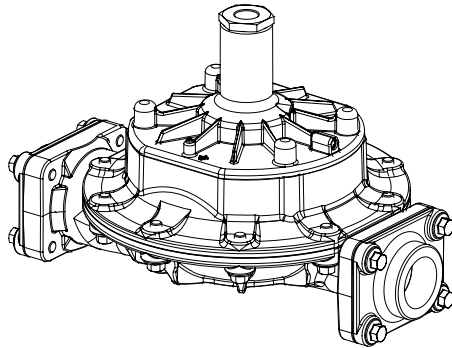

METALLIC
ALUMINIUM / IRON / STAINLESS STEEL

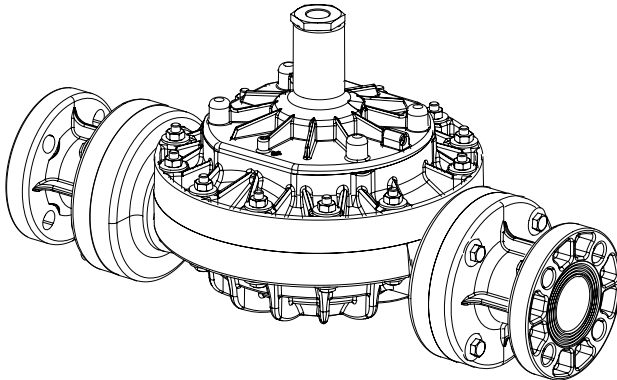

NON-METALLIC
POLYPROPYLENE

2" APD20 PULSATION DAMPENER



Main Instruction Book Includes All Languages

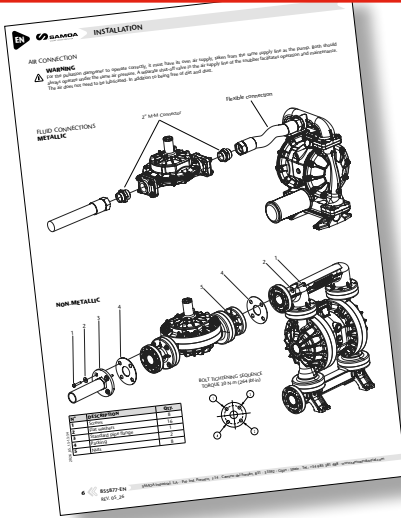

Maintenance Spare Parts Kits

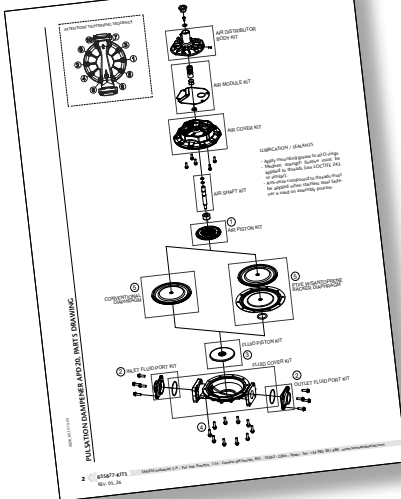



Instruction books By Language Requested

EN
INSTRUCTIONS



ES
INSTRUCCIONES



FR
INSTRUCTIONS



DE
BEDIENUNGS-
ANLEITUNG



WARNING / ADVERTENCIA / AVERTISSEMENT / WARNUNG

Carefully read user manual and its warnings before using the equipment.

Lea atentamente el manual de instrucciones y sus advertencias antes de empezar a operar con el equipo.

Lisez attentivement le manuel d'instructions et les avertissements qu'il contient avant de commencer l'utilisation de l'appareil.

Lesen Sie das Benutzerhandbuch und die darin enthaltenen Warnhinweise sorgfältig durch, bevor Sie das Gerät benutzen.

**EC CONFORMITY DECLARATION / DECLARATION CE DE CONFORMIDAD
DÉCLARATION DE CONFORMITÉ CE / EG-KONFORMITÄTSERKLÄRUNG**



- EN** SAMOA INDUSTRIAL, S.A., Pol. Ind. Porceyo, I-14 · Camino del Fontán, 831 · 33392 - Gijón - Spain, declares that the product(s): **APD20X-XXX-X** conform(s) with the EU Directive(s): **2006/42/EC**
- ES** SAMOA INDUSTRIAL, S.A., Pol. Ind. Porceyo, I-14 · Camino del Fontán, 831 · 33392 - Gijón - España, declara que el(los) producto(s): **APD20X-XXX-X** cumple(n) con la(s) Directiva(s) de la Unión Europea: **2006/42/CE**
- FR** SAMOA INDUSTRIAL, S.A., Pol. Ind. Porceyo, I-14 · Camino del Fontán, 831 · 33392 - Gijón- Espagne, déclare que le(s) produit(s): **APD20X-XXX-X** est(sont) conforme(s) à la (aux) directive(s) européenne(s): **2006/42/CE**
- DE** SAMOA INDUSTRIAL, S.A., Pol. Ind. Porceyo, I-14 · Camino del Fontán, 831 · 33392 - Gijón- Spanien, bestätigt hiermit, dass das (die) Produkt (e): **APD20X-XXX-X** der (den) EG-Richtlinie(n): **2006/42/EG** entspricht (entsprechen).

For SAMOA INDUSTRIAL, S.A.
Por SAMOA INDUSTRIAL, S.A.
Pour SAMOA INDUSTRIAL, S.A.
Für SAMOA INDUSTRIAL, S.A.

Pedro E. Prallong Álvarez
Production Director
Director de Producción
Directeur de Production
Produktionsleiter
Direttore di Produzione
Produktionschef

RU

EAC

**ЕВРАЗИЙСКОЕ СООТВЕТСТВИЕ
DIAPHRAGM PUMPS**

EAC

Сертификат соответствия:

ЕАЭС N RU Д-ES.РА06.В.40424/25, срок действия с 28.07.2025 по 27.07.2030, выдан органом по сертификации Федеральная служба по аккредитации; Адрес 117997, г. Москва, ул. Вавилова, д. 7. Телефон: +7 (495) 539 26 70, e-mail: fgis@fsa.gov.ru.

Дата производства указана на маркировке изделия

Транспортировка

Изделие должно транспортироваться в заводской упаковке для защиты от повреждений и влаги.

Хранение

Изделие должно храниться запечатанным, в хорошо проветриваемом и сухом помещении.

Утилизация

Выполняйте национальные правила утилизации и переработки отслужившего оборудования, упаковки и принадлежностей.